

Features

- Cartridge style pressure relief, reducing and flow control valves
- Sequence valves allowing flow when a preset pressure is reached in a 3rd line.
- Cartridge for use in custom designed manifold
- Optional aluminum anodized body available
- Industry standard cartridge thread
- For use with mineral based oils
- From -30°C to 120°C operation



R-Relief

Ordering Details

V	Valve																																																							
C	Cartridge																																																							
R-	Valve type:																																																							
08-2-	Cavity Size (page 3)																																																							
O4-	Body Port Size (blank for cartridge only)																																																							
H	Adjustment	<table border="1"> <thead> <tr> <th>Valve Type</th> <th>Code</th> <th>Description</th> </tr> </thead> <tbody> <tr> <td>R, R2, U and Q-8-3 (relief and reducing)</td> <td>H</td> <td>Allen wrench with Hex nut</td> </tr> <tr> <td>F AND Q10-3 (flow)</td> <td>R</td> <td>Rotary knob</td> </tr> </tbody> </table>	Valve Type	Code	Description	R, R2, U and Q-8-3 (relief and reducing)	H	Allen wrench with Hex nut	F AND Q10-3 (flow)	R	Rotary knob																																													
Valve Type	Code	Description																																																						
R, R2, U and Q-8-3 (relief and reducing)	H	Allen wrench with Hex nut																																																						
F AND Q10-3 (flow)	R	Rotary knob																																																						
36-	Spring Opening Pressure (blank for "F" flow valve):																																																							
1	Series	<table border="1"> <thead> <tr> <th>Valve Type</th> <th>Code</th> <th>Spring pressure adjustment range (PSI)</th> </tr> </thead> <tbody> <tr> <td rowspan="4">VCR-08-2</td> <td>10</td> <td>290-1000</td> </tr> <tr> <td>23</td> <td>580-2300</td> </tr> <tr> <td>36</td> <td>1160-3600</td> </tr> <tr> <td></td> <td></td> </tr> <tr> <td rowspan="4">VCR-10-2</td> <td>6</td> <td>44-600</td> </tr> <tr> <td>12</td> <td>145-1200</td> </tr> <tr> <td>23</td> <td>247-2300</td> </tr> <tr> <td>30</td> <td>290-3000</td> </tr> <tr> <td rowspan="2">VCR-T10A</td> <td>30</td> <td>507-3000</td> </tr> <tr> <td>45</td> <td>797-4500</td> </tr> <tr> <td rowspan="3">VCR2</td> <td>10</td> <td>102-1000</td> </tr> <tr> <td>30</td> <td>508-3000</td> </tr> <tr> <td>58</td> <td>725-5800</td> </tr> <tr> <td>VCR-T3A</td> <td>30</td> <td>507-3000</td> </tr> <tr> <td rowspan="3">VCU-08-3</td> <td>6</td> <td>100-600</td> </tr> <tr> <td>12</td> <td>300-1200</td> </tr> <tr> <td>22</td> <td>500-2200</td> </tr> <tr> <td rowspan="2">VCU-T11A</td> <td>4</td> <td>25-400</td> </tr> <tr> <td>30</td> <td>500-3000</td> </tr> <tr> <td>VCQ-8-3</td> <td>30</td> <td>50-3000</td> </tr> <tr> <td>VCQ-10-3</td> <td>21</td> <td>210-2100</td> </tr> </tbody> </table>	Valve Type	Code	Spring pressure adjustment range (PSI)	VCR-08-2	10	290-1000	23	580-2300	36	1160-3600			VCR-10-2	6	44-600	12	145-1200	23	247-2300	30	290-3000	VCR-T10A	30	507-3000	45	797-4500	VCR2	10	102-1000	30	508-3000	58	725-5800	VCR-T3A	30	507-3000	VCU-08-3	6	100-600	12	300-1200	22	500-2200	VCU-T11A	4	25-400	30	500-3000	VCQ-8-3	30	50-3000	VCQ-10-3	21	210-2100
Valve Type	Code	Spring pressure adjustment range (PSI)																																																						
VCR-08-2	10	290-1000																																																						
	23	580-2300																																																						
	36	1160-3600																																																						
VCR-10-2	6	44-600																																																						
	12	145-1200																																																						
	23	247-2300																																																						
	30	290-3000																																																						
VCR-T10A	30	507-3000																																																						
	45	797-4500																																																						
VCR2	10	102-1000																																																						
	30	508-3000																																																						
	58	725-5800																																																						
VCR-T3A	30	507-3000																																																						
VCU-08-3	6	100-600																																																						
	12	300-1200																																																						
	22	500-2200																																																						
VCU-T11A	4	25-400																																																						
	30	500-3000																																																						
VCQ-8-3	30	50-3000																																																						
VCQ-10-3	21	210-2100																																																						

Valve Type	Port Size, SAE O-ring	Cavity Size Code	Max. Flow lpm	Max. Pressure Cartridge Bar	Max. Pressure Body Bar	Leakage at Max. Pressure cc/min
R-Relief	4	08-2	10	270	210	≤0.25 (80% of max. pressure)
	8	10-2	37.8	207	210	≤0.25 (80% of max. pressure)
	12	T10A	95	350	210	≤0.7
	16	T3A	200	350	210	≤0.7
R2-Relief	6	08-2	30	400	210	≤0.3
U-Reducing	4	08-3	11.4	207	210	≤82
	8	T11A	40	350	210	≤30
F-Flow	6	08-2	30	250	210	≤0.15
	8	10-2	45	250	210	≤0.15
Q-Sequence	6	8-3	22.8	350	350	≤82 (85% of max. pressure)
	8	10-3	38	207	210	≤82 (90% of max. pressure)

Example Part Number: VCR-08-2-O4-H-36-1

Dimensions (mm)

VCR-08-2..H

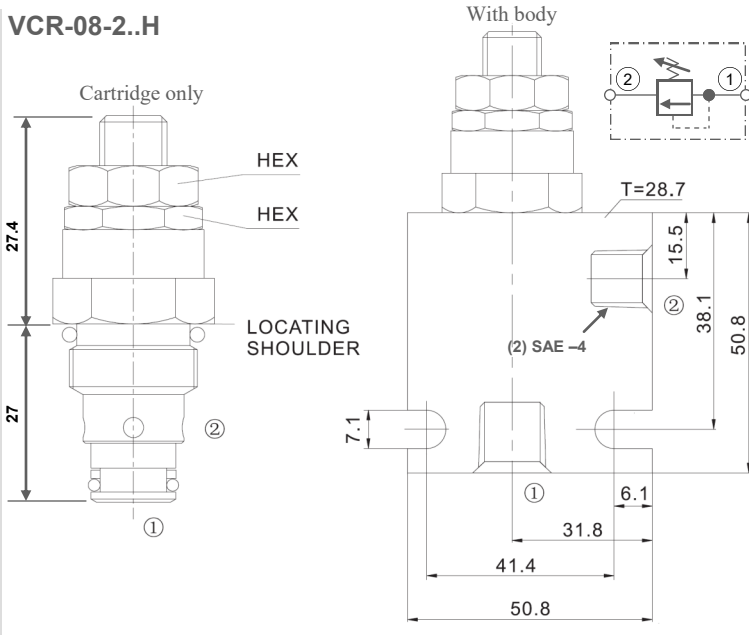

VCR-10-2..H

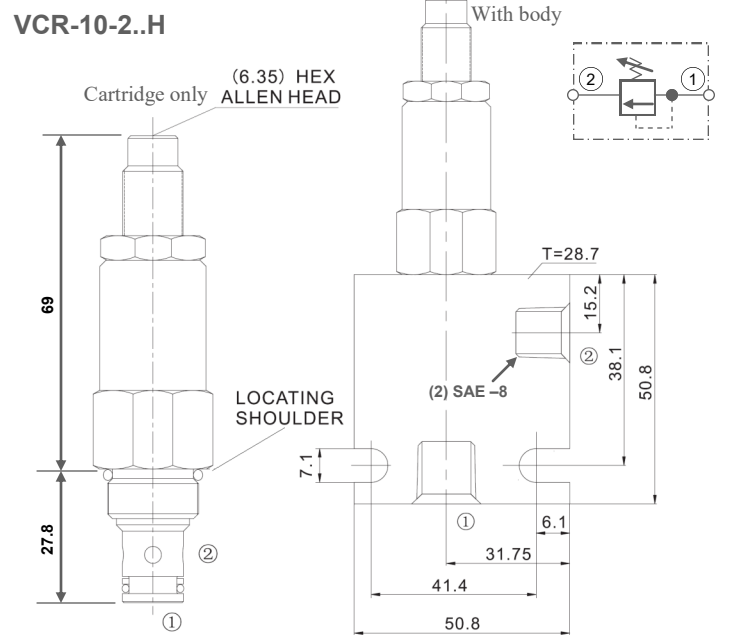

VCR-T10A..H

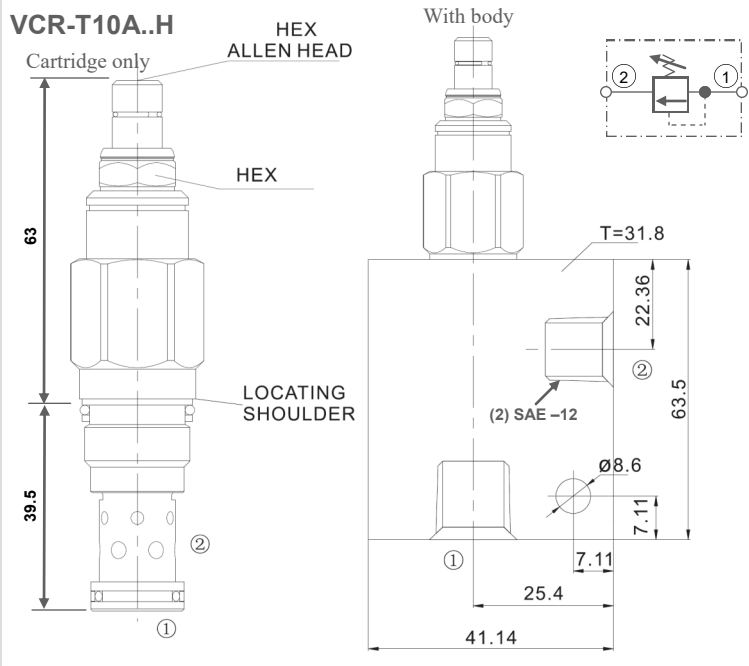

VCR2-08-2..H

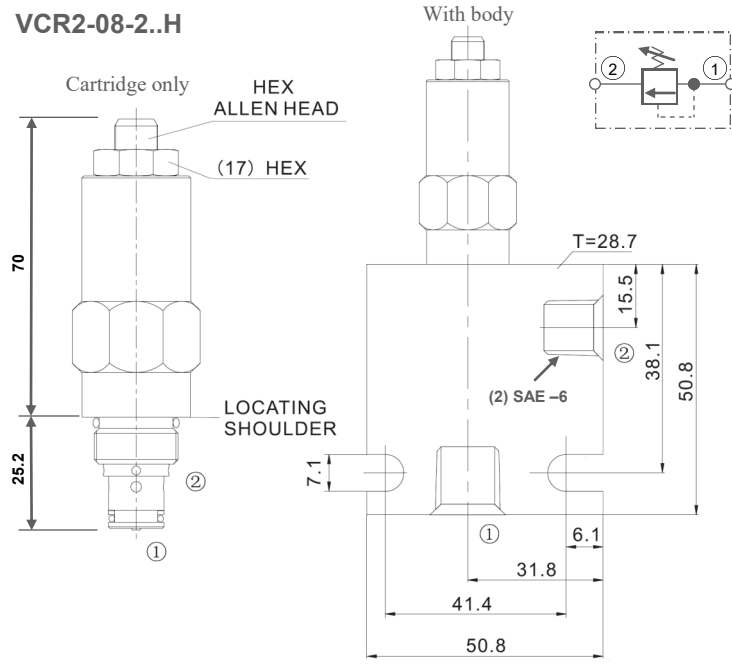

VCR-T3A..H

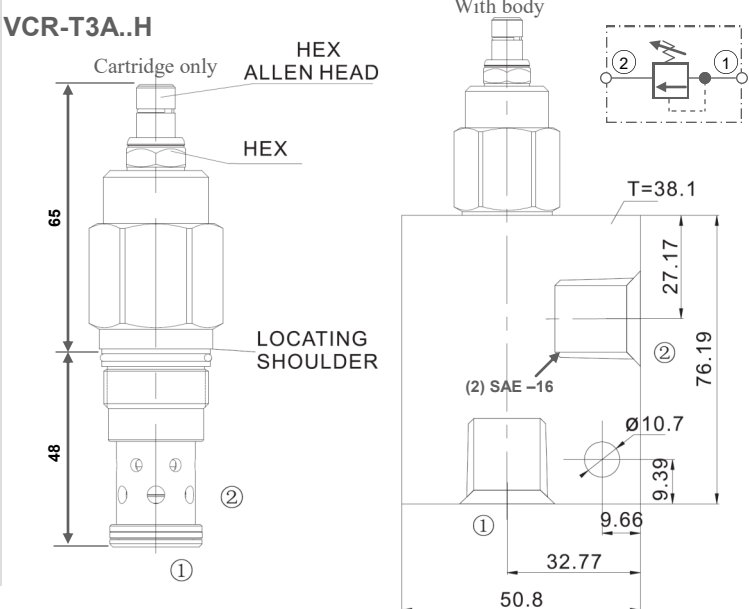

Relieving

Dimensions (mm)

VCU-08-3..H

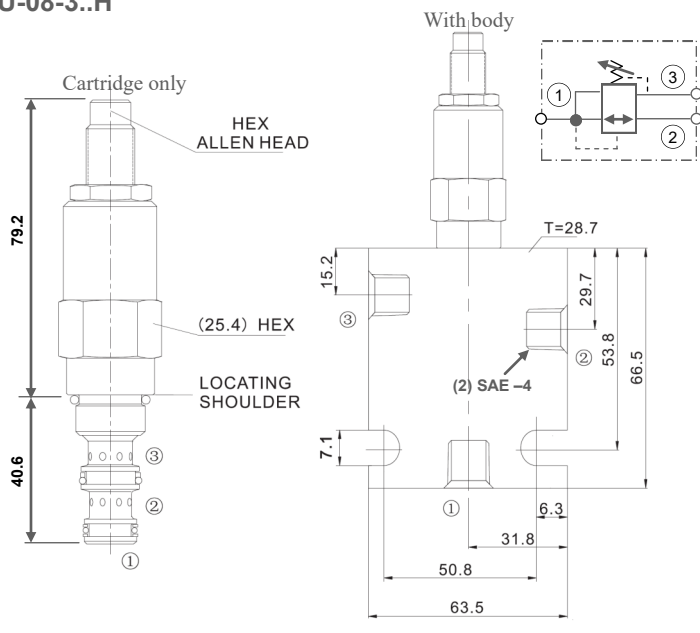

VCU-T11A..H

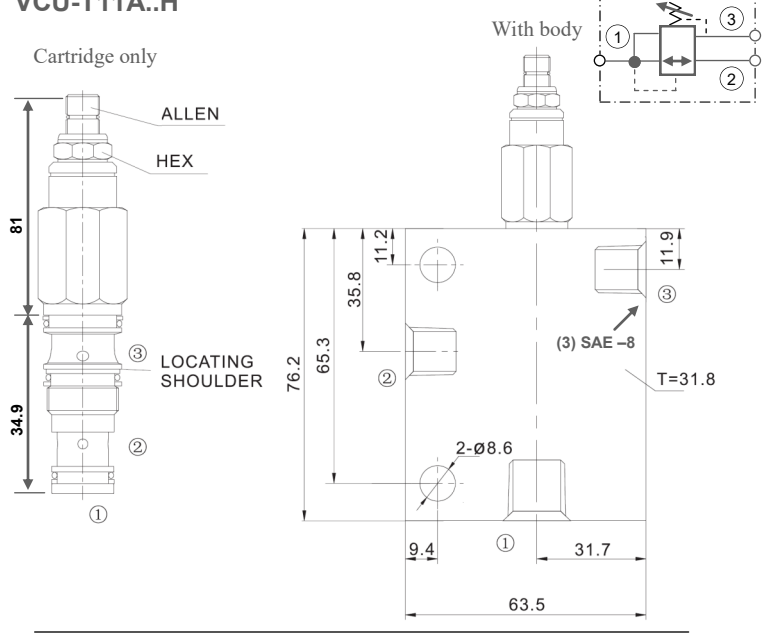

VCF-8-2..R

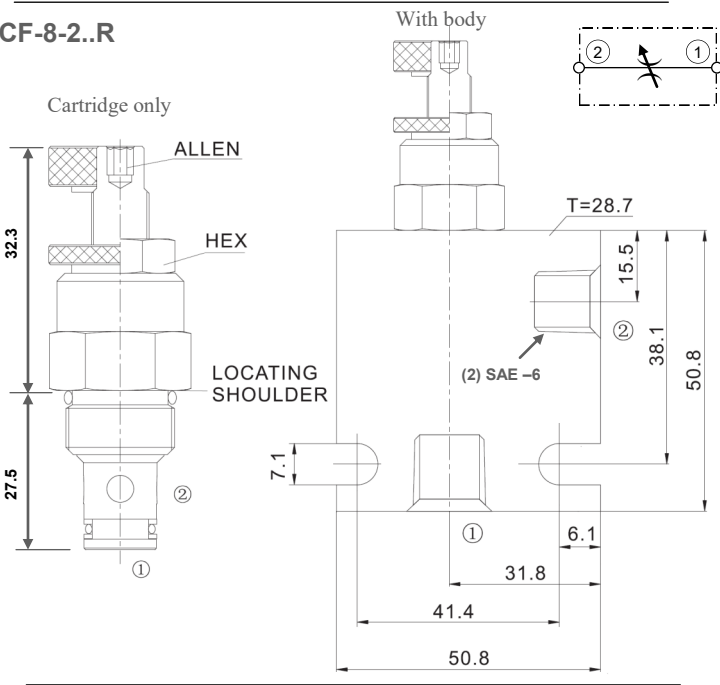

VCF-10-2..R

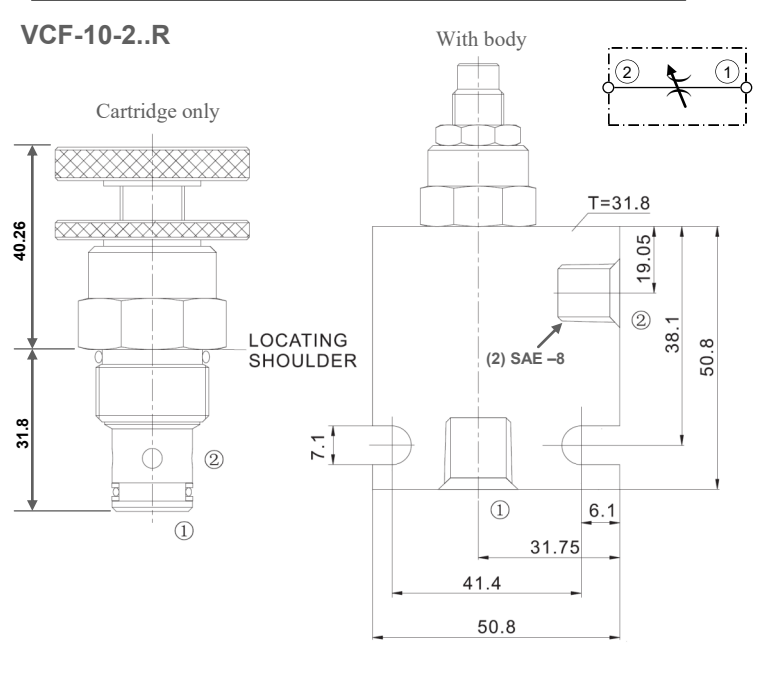

VCQ-8-3..H

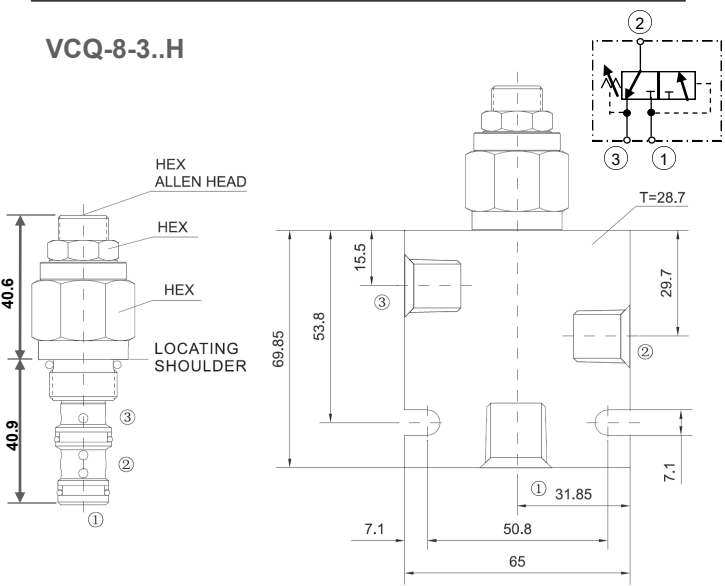

VCQ-10-3..R

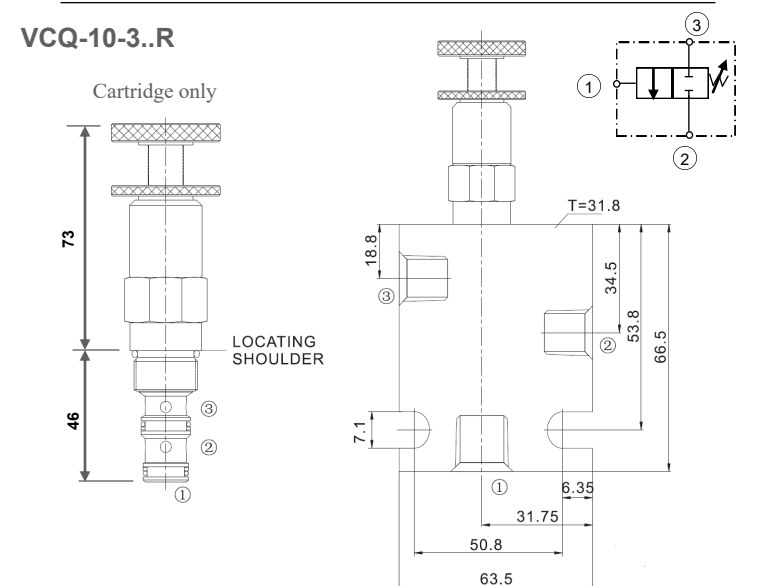

Reducing

Flow

Sequence

Cavity Dimensions (mm)

08-2

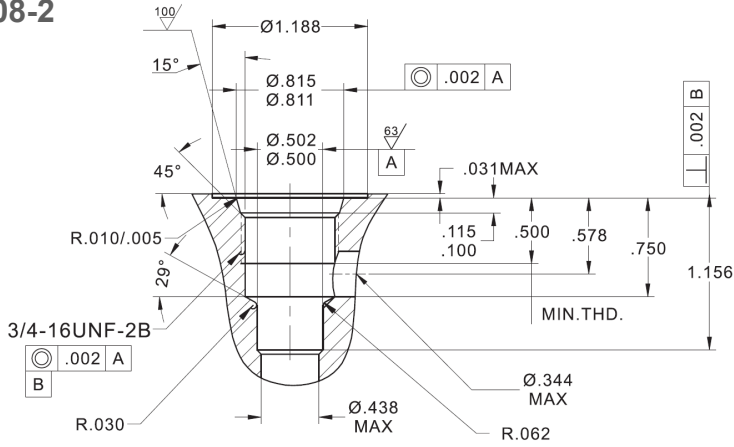

08-3

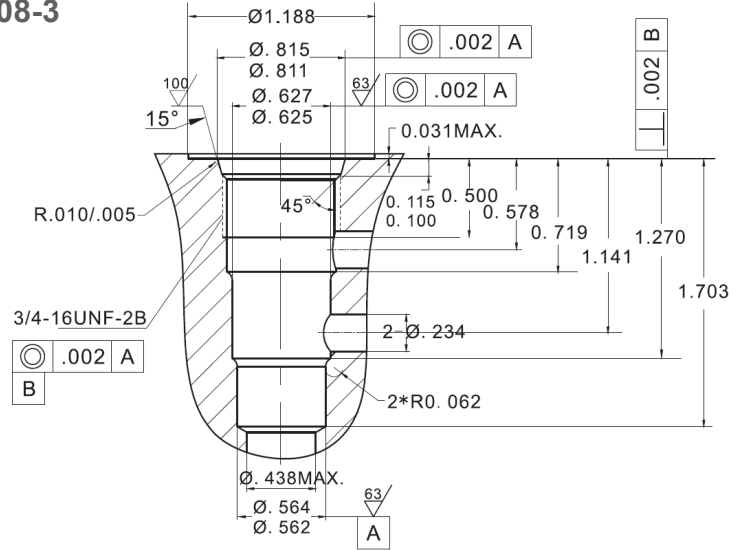

10-2

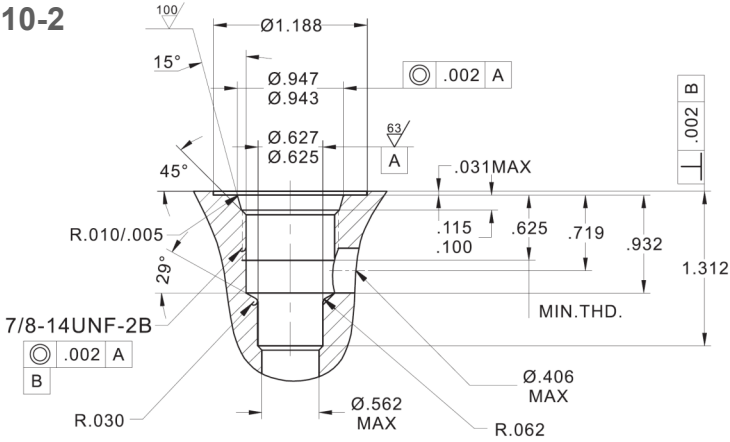

10-3

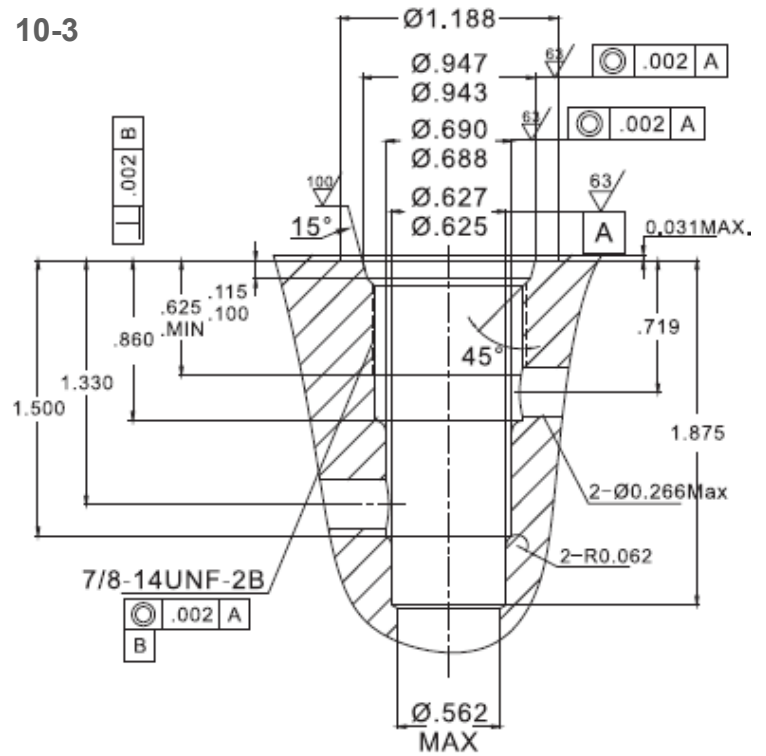

T3A

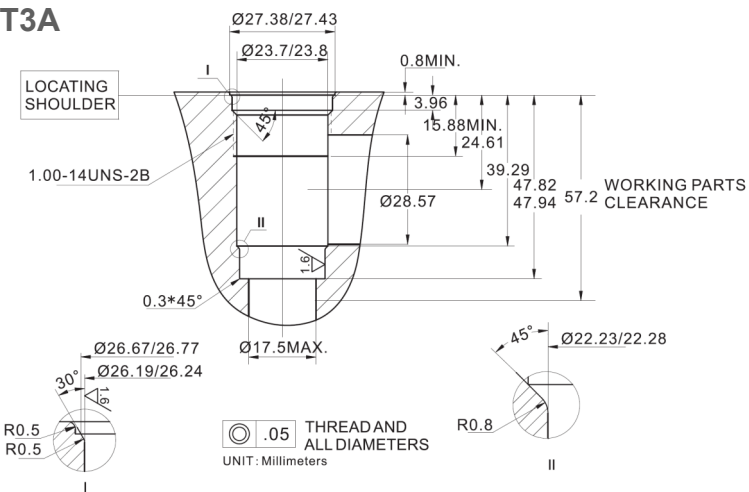

T11A

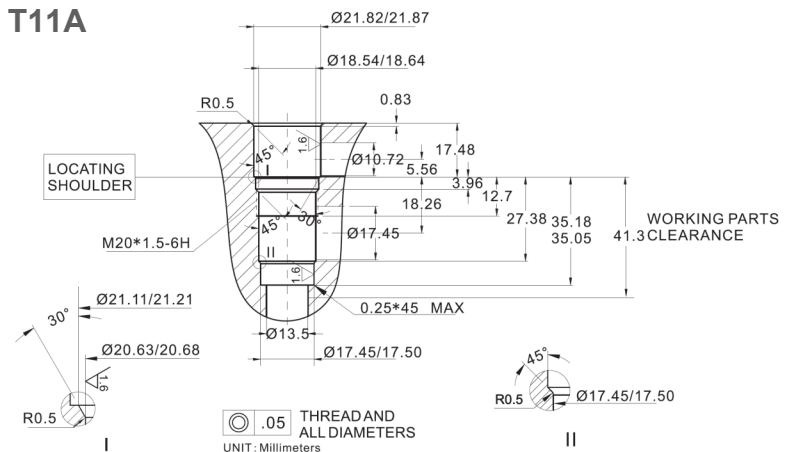

T10A

